

Ax60

CO2 Safety Monitor



The Ax60 is a wall mountable carbon dioxide (CO₂) detector which allows multiple placement of CO₂ Alarms and Sensor units which are connected to a Central Display. Each CO₂ Alarm unit not only has an audible sounder but also utilises a high-intensity LED strobe light - perfect for warning of danger in noisy environments.

The Ax60 gives warning of an increase in CO₂ by offering three levels of alarm. A low alarm is triggered by 15,000 ppm (1.5%) CO₂; a high alarm by 30,000 ppm (3%) CO₂; and a time-weighted average (TWA) alarm of 5000 ppm (0.5%) CO₂ over the previous eight hours (average exposure measurement).

KEY FEATURES

Multi-point CO₂ detector

Approved by leading global fast food outlet

Central unit can be checked away from the danger zone

5-year sensor and electronics warranty

Low maintenance

TWA monitoring

Optional extras protector kit

INDUSTRIES



Unless your local regulations state otherwise the Ax60 will NEVER need calibrating.

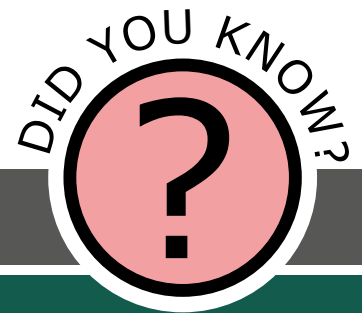
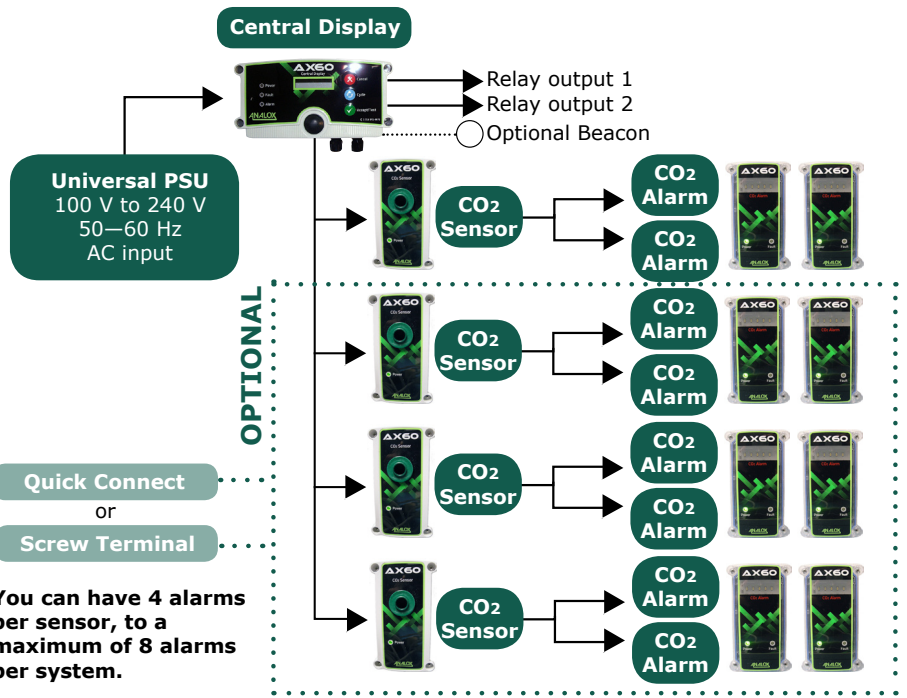

Providing niche custom gas detection since 1981

ANALOX
Sensor Technology

SPECIFICATIONS

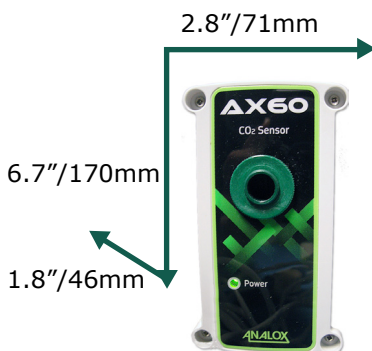
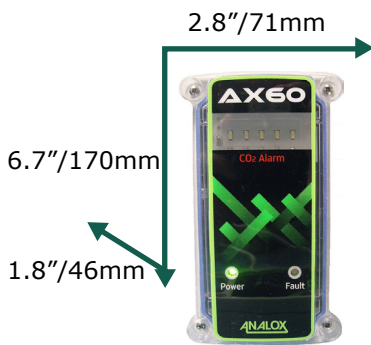

System

Warranty - 5 years

Warm-up time - 40 seconds

Operating temperature range - -5°C to $+50^{\circ}\text{C}$,
 $+23^{\circ}\text{F}$ to $+122^{\circ}\text{F}$

Approvals - CE, EN50270, IEC 61010 (UL),
DIN 6653 (TUV)

Central Display

Display - LCD dot matrix (backlit)

Relays - 2 off, normally open. Rating 1 A/30 V AC/DC

IP Rating - IP54

CO2 Alarm

Strobe - white LED strobe > 100 cd
(optional blue or red filter).

Sounder - min 80 dBA @3 m (9.8 feet).

IP Rating - IP55

CO2 Sensor

Gas detected - carbon dioxide

Measurement technique - infrared

Range - 0.1% to 5%

Alarm setpoints - 0.5% (8 hour TWA), 1.5%, 3.0%

IP Rating - IP55

Analox has a policy of continuous improvement and we reserve the right to upgrade or change specifications without prior notice.
Full technical specifications are available upon request and can be found in the User Manual.
If you require a datasheet in another language please contact us.

www.analoxsensortechnology.com



UK: +44 (0) 1642 711400

US: +1 (714) 891 4478



info@analox.biz

ANALOX
Sensor Technology